

Eaton RF Mesh Technical Overview

Owen Parry

William Corbalis

Chowdhary Shashikant

5/9/2023



Powering Business Worldwide

© 2023 Eaton. All rights reserved.

Objectives

- Provide technical overview of RF mesh fundamentals
- Provide knowledge of RF Network deployment, formation and dynamic network behavior
- Provide overview of RF Applications
- Review Network Troubleshooting use cases

Agenda

- Introduction to Wireless communications
- Eaton RF Mesh Network Fundamentals
- Deployment
- Eaton RF Network Operation
- Network Troubleshooting
- Applications
- Q&A

Introduction to Wireless Communications

Network Types

Tower

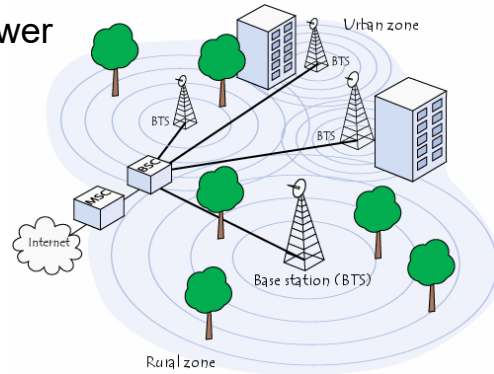

Cell

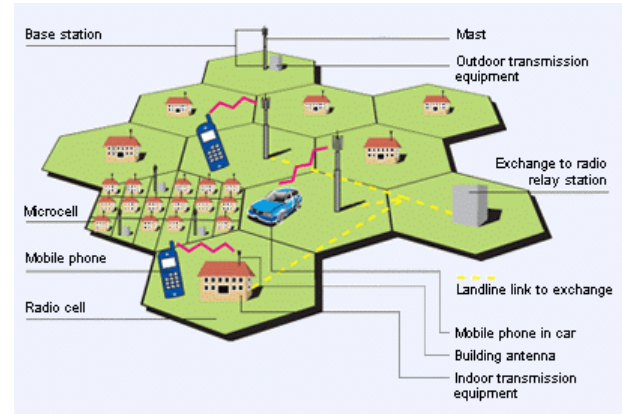

Mesh

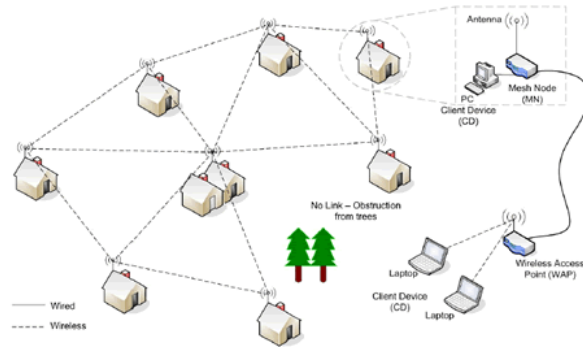

Eaton's RF Mesh

- Self-Organizing and Self-Healing
 - No configuring of the nodes at the utility or in the field
 - Nodes independently determine the most efficient method to get to the gateway
 - Nodes automatically identify alternate routes to the gateway when primary communications paths are interrupted
- Easily Expandable/Scalable
 - Easy to add additional gateway when required to expand network
- Secure and Interoperable
 - Mutual authentication and derived encryption keys for each data exchange between nodes
- OTA Firmware Updates
- Single Network
 - A full two way network AND a single Software Platform for Electric, Water, Gas, DR and DA

Eaton's RF Network Specification

- Spectrum
 - ISM bands - 902-928 MHz frequency product (25 MHz available spectrum (50 channels))
 - Frequency Hopping Spread Spectrum (FHSS)
- Throughput
 - Up to 153 kbps data rate with Auto-Optimization
- Variable Power Optimization
 - 125mW to 1W
- Industry Leading Data Transport
 - Up to 96 metric points in the daily report
 - 15 User Defined Interval Data Channels (kWh, voltage, TOU, kVAR/kVARh, etc.)
 - Over 50 different alarms and events
- Security
 - Security built-in to all node-to-node communications. End-to-end security, with mutual authentication and derived encryption keys for each node data exchange.



Communications Range

- Communication Range in an RF network is affected by the following factors:
 - Power
 - Receive Sensitivity (Data Rate)
 - Path Loss

Communications Range - Path Loss

- Distance
Received power goes down by the square of the distance between nodes
- Obstacles
Topography (i.e. walls, trees, buildings, hills, mountains...)
- Reflections & Multi-Path
Reflected radio signals take different length paths and interfere
- Diffraction
Gives the effect that the signal can bend around corners
- Scattering
Due to small particles, air pollutants and moisture droplets along the path

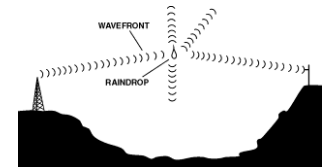
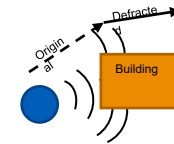

Communications Range - Power

- Total Network Communications Range or Distance =
Node to node distance X number of hops
- Node to node distance is affected by:
 - Transmit Power of Source Node
 - Transmit Power Limited by FCC Regulations
 - Transmit Power Limited by Source of Power (i.e. Battery)
 - Transmit Power Affected by Type of Antenna (Gateway, Relay)

Communications Range - Data Rate

- Receive Sensitivity
 - Measure of how well the receiver performs
 - Defined as the power of the weakest signal the receiver can detect
 - Function of data rate
- Rate vs. Range
 - The lower the data rate, the longer the transmission range
 - The higher the data rate, the shorter the effective range of the transmission
- Rate vs. Throughput
 - Lower data rate = lower throughput
 - Higher data rate = higher throughput

Eaton RF Mesh Network Fundamentals

RF Mesh Components

- Our mesh solution is comprised of the following elements:
 - Yukon/Network Manager
 - Gateway
 - Electric Nodes
 - Single Phase Meters
 - Polyphase Meters
 - DR Switches
 - DA RTUs
 - Battery Nodes
 - Water
 - Gas (New)
 - IP Link Nodes (New)
 - WiFi
 - Cellular (Future)
 - Relays
 - Network Runner



RF Mesh Network Components

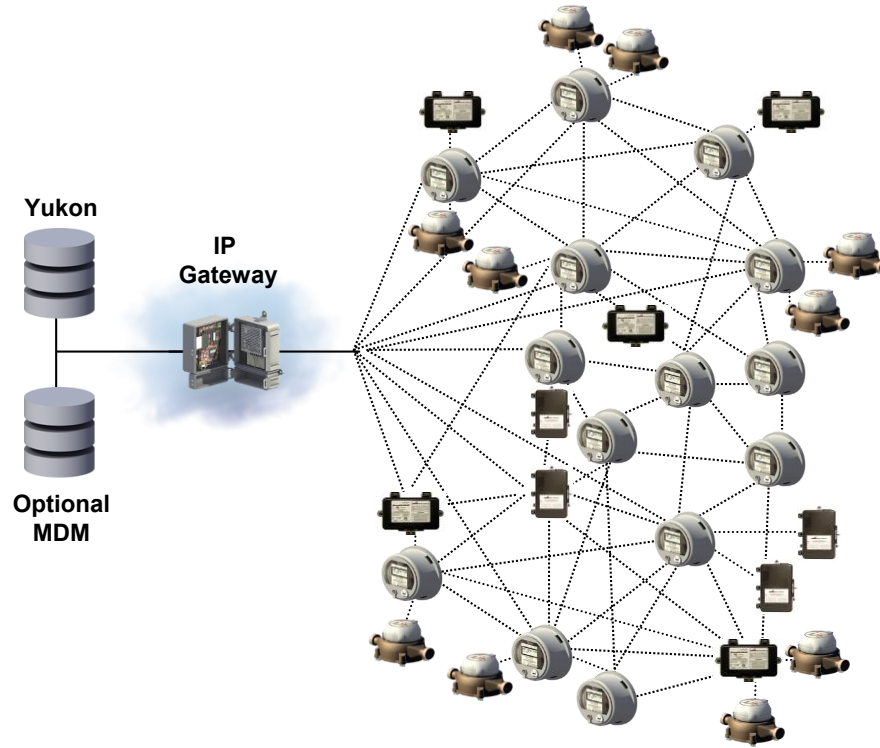

Powering Business Worldwide

RF Network Manager

- Acts as a middleware between Yukon and Gateway
- Manages the Gateways and performs network monitoring functions
 - Network Flow Control
 - Maintains a Database
- Provides diagnostics for the network and nodes

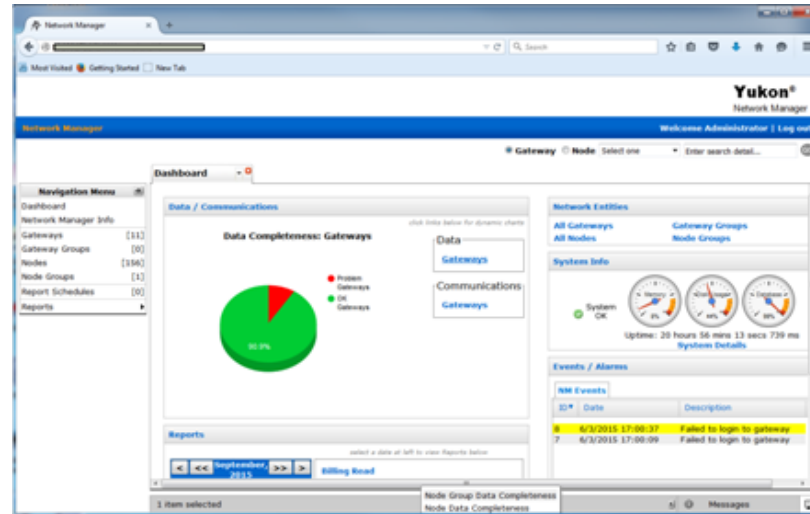

RFN Hardware

- Gateway - Network Bridge, Collector, between RF wireless mesh and IP wide area network, backhaul support to Network Manager, Yukon
- Powered Nodes - Support two-way unicast and broadcast messaging, Metrology, Events and alarms, ...
- Battery Nodes - Support multiple vendor water registers, Gas, OTA updates, ...
- Relays - Build out infrastructure to form robust mesh, extend RF communications into rural areas
- IPLink WiFi Node - Meter functions, network bridge between RF wireless mesh and utility network
- Network Runner - Provides configuration and diagnostic field support

Deployment

RF Network Deployment: Gateway Planning

- A propagation study is done as part of initial network design:
 1. Connectivity
 2. Network formation
 3. Capacity
- Gateway locations are proposed as a result of the study
- Final gateway locations are decided upon based on initial proposed location and the constraints imposed by back-haul locations

Modifications for Constraints



RF Network Deployment: Backhaul planning

- Backhaul is critical to system performance
 - Always available 2-way communication
 - IT infrastructure is setup correctly for access to:
 - NM and Yukon servers
 - NTP server that was configured at Gateways
 - At least 128Kbps of backhaul capacity per gateway
 - MTU size of 1500 bytes
 - Unreliable backhaul can affect:
 - Data completeness of interval data
 - Remote Connects and Disconnects
 - On Demand Reads
 - Demand Response events

RF Network Deployment

- The order in which the elements that comprise the RF network are deployed is CRITICAL to how quickly the RF network forms
- Order of recommended installation and deployment
 - Yukon and RF Network Manager installation should be planned first
 - Install Gateways
 - Backhaul considerations (wired, wireless)
 - Configure the gateways and setup backhaul communications with RF Network Manager
 - Install recommended relays starting closest to the gateway
 - Install electric nodes outwards from gateway
 - Revisit network coverage after network is discovered and install additional relays or gateways as needed
 - Install battery nodes (water, etc.)

RF Network Deployment

- Install and setup Yukon/NM
- Install gateways and configure backhaul

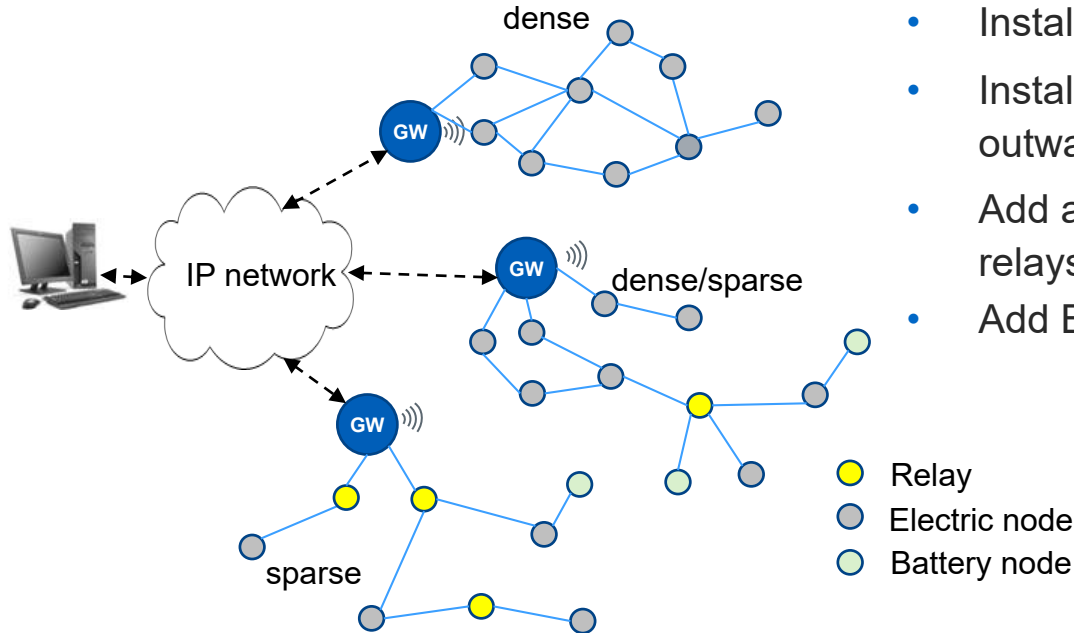

- Install relays
- Install electric nodes outwards from gateway
- Add additional relays as needed
- Add Battery nodes

RFN Gateway Configuration

- Requires minimum configuration
 - Ethernet IP address, NTP Server IP address
 - GPS Coordinates
 - Gateway must be configured using the RF Field Tool via the Gateway Commissioning Workflow

RFN Gateway Configuration

The screenshot shows the 'Gateway Commissioning' configuration page in the Eaton Network Runner application. The page is divided into two tabs: 'Configuration' (selected) and 'Activation'. The configuration fields are as follows:

- NTP Servers:** 10.106.171.161 129.6.15.29 151.110.126.15
- Ethernet IP:** 10.106.171.217
- Ethernet Mask:** 255.255.254.0
- Ethernet Default GW:** 10.106.170.1
- APN:** (empty field)
- APN User:** (empty field)
- APN Password:** (empty field)
- Interface:** Cellular Modem
- ICMP:** Disabled

The bottom of the screen features a control bar with 'Update', 'Set', and 'Cancel' buttons.

Node Configuration

- Electric nodes configured at production (Plug-n-play)
- New Water nodes configured at production
- WiFi devices require additional configuration
- All devices may be optionally configured with GPS coordinates
 - May also be imported into Yukon

Eaton RF Network Operation

Network Concepts: Routes

- A Route defines the path from one node to another
- Four major components:
 - Destination – the GW to be reached
 - Next hop – the node where the data is forwarded to reach destination
 - Cost – Quantitative representation of the link quality through the route
 - Hop – Number of hops to the destination
- Node objective: Always find the route with lowest cost to Gateway
- The 'primary route' is the route to the gateway

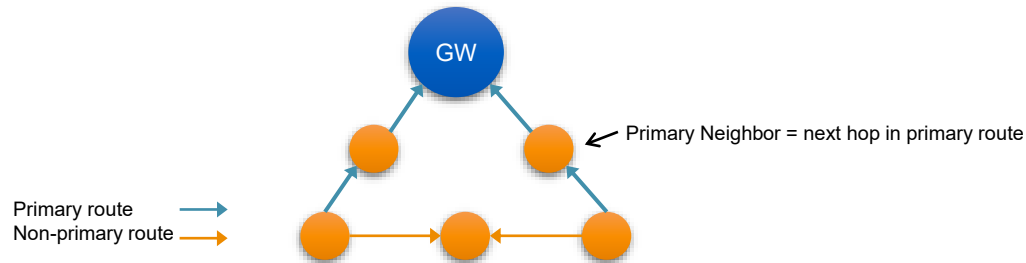

Network Concepts: Neighbors and Route Types

- The next hop node in primary route to Gateway is 'Primary Forward' (PF)
- A group of nodes using a node as their primary forward are 'descendants' of that node
- The next hop node from GW down to a descendant is 'Primary Reverse' (PR)
- All neighbors used as next hop for primary routes are 'Primary Neighbors'
- Neighbors not in primary route are 'Secondary Neighbors'

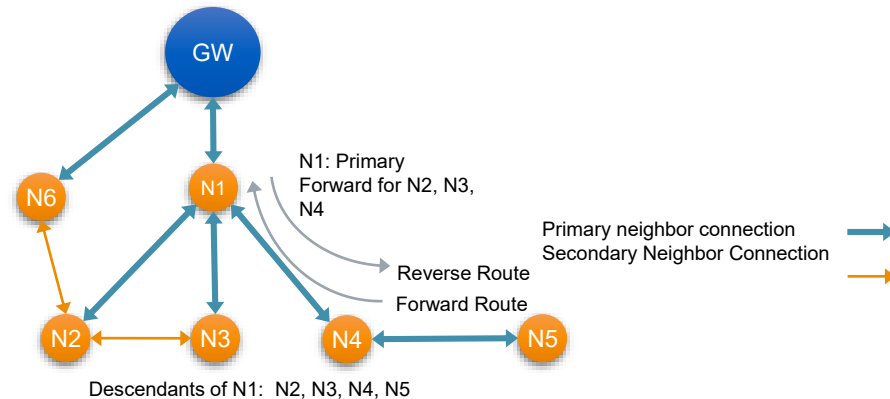

Initial Network Formation: Electric Node

- Upon power up, the Gateway starts 'visibility' broadcast
- The new nodes, invisible to the rest of the network, wait for the broadcast containing gateway information.

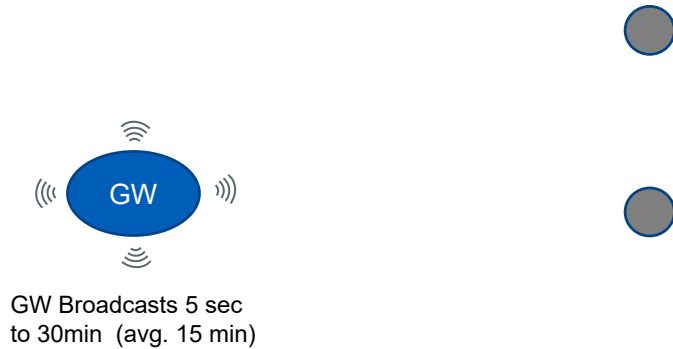

Initial Network Formation: Electric Node

- A node that can hear the broadcast, schedules a connection to the gateway
- During the connection, the node and gateway exchange route information and the Gateway learns the node's information.
- The node becomes READY once the Network Manager receives node's identification information and its route to the Gateway.

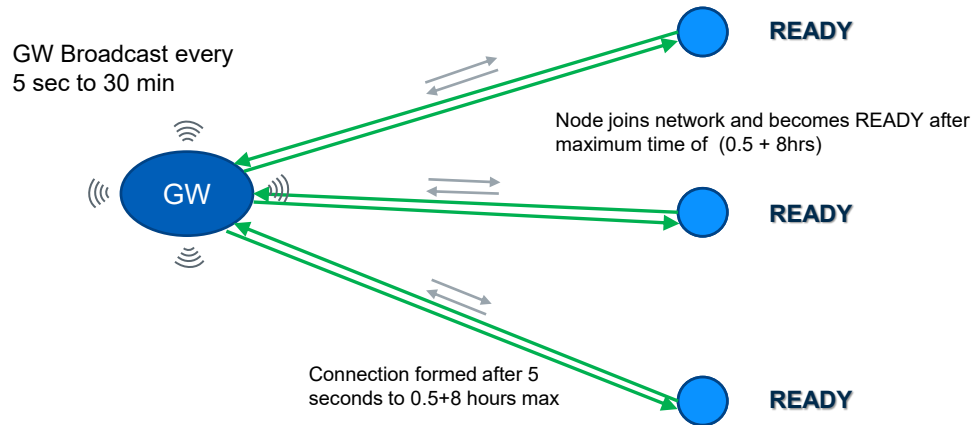

Initial Network Formation: Electric Node

- The node is now a 'one hop node' and 'In Network'
- It starts its own visibility broadcast

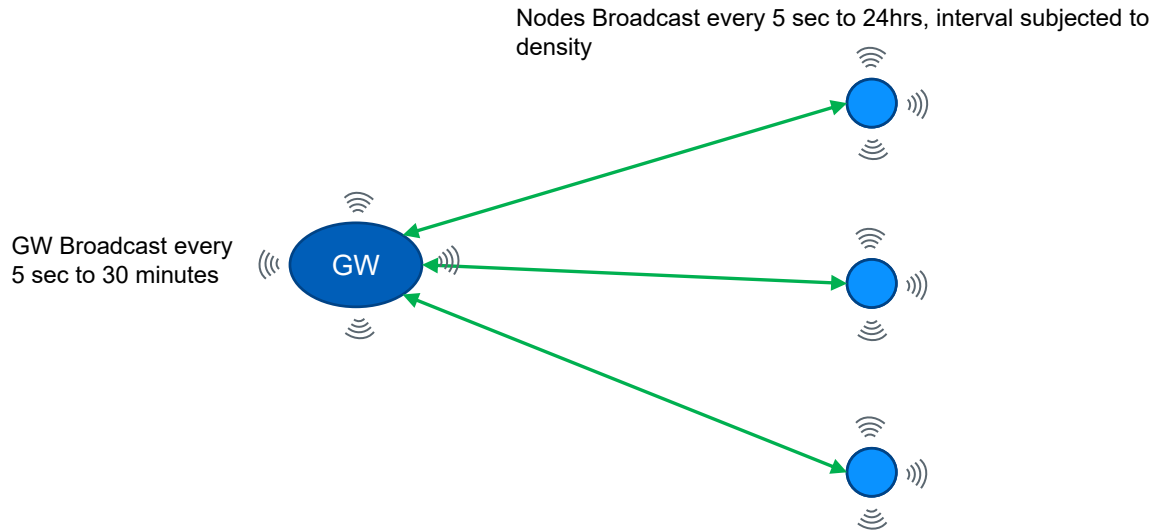

Initial Network Formation: Electric Node

- The nodes that can hear 'one-hoppers' join next
- Second hop is formed

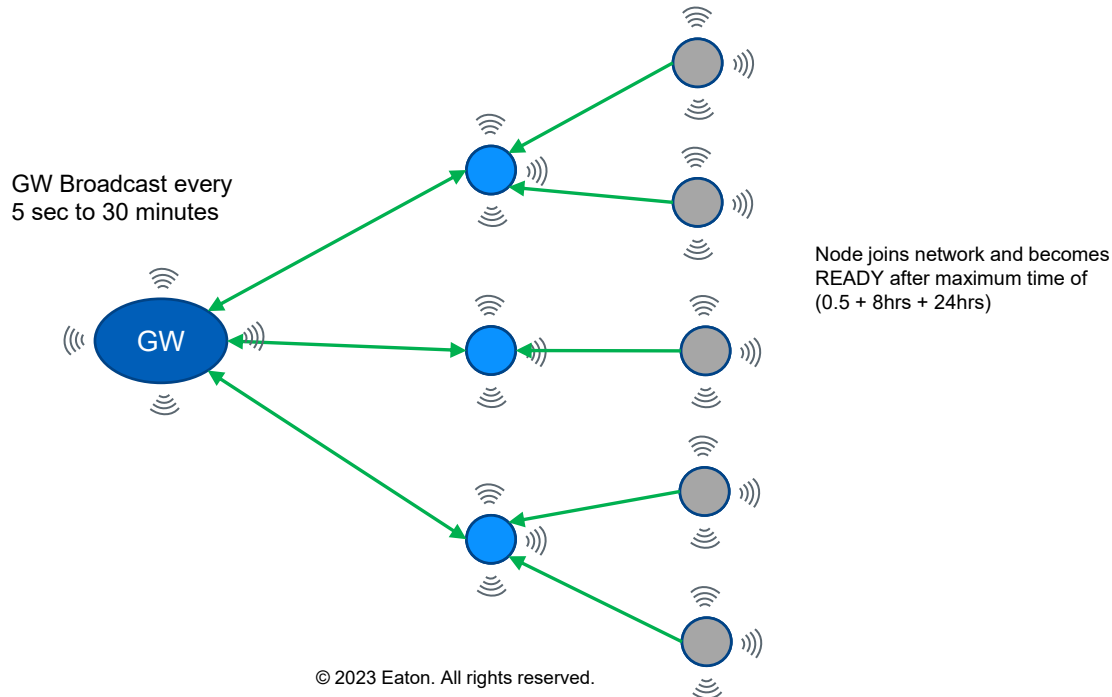

Initial Network Formation: Electric Node

- The sequence of broadcast, connection, route discovery follows, more hops are added to the gateway
- Network thus forms outward from the gateway to the leaf nodes

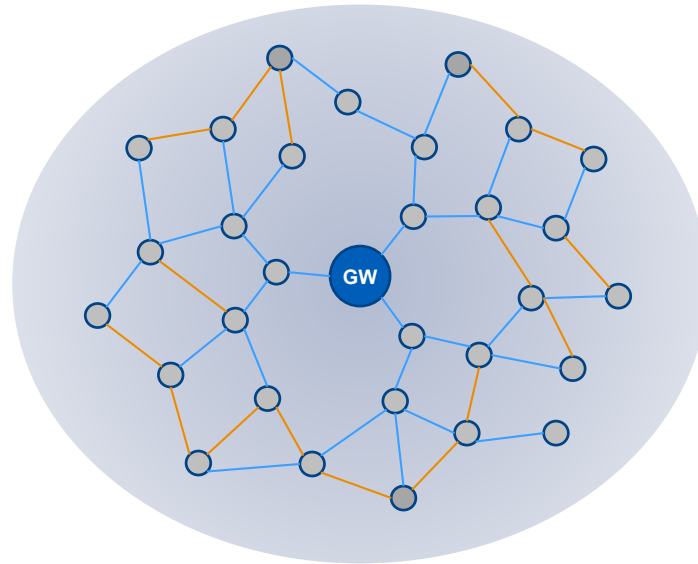

Initial Network Formation: Battery Node

- Out of network Battery node broadcasts its presence
- Nearby electric nodes schedule connections
- The first electric node to make a connection negotiates rendezvous time with the battery node
- The battery node joins network and stops broadcasting

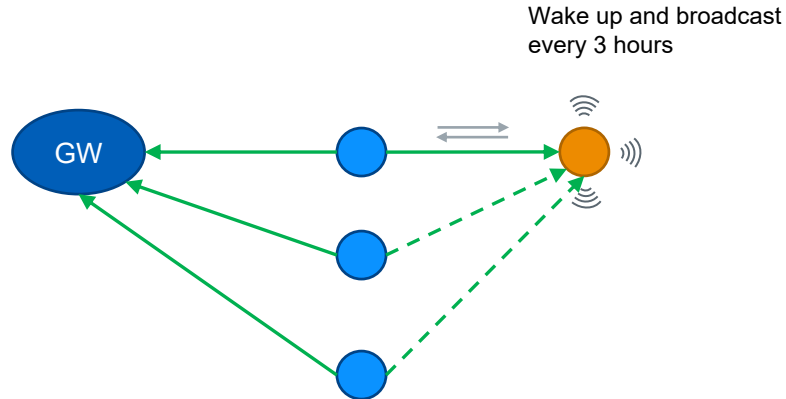

Fast Network Join

- RF Field Tool commands a newly installed RF device to join Network immediately
- The new device broadcasts its presence to the network at various power levels
- If an 'in-network' node hears the broadcast, it connects to the new device within a minute, does time sync and provides Gateway route information

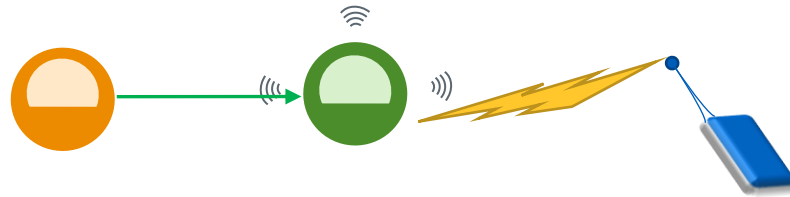

Fast Network Join

- Newly installed node identification and routing path is immediately sent to the Gateway and Network Manager
- Node becomes READY within 5 minutes after Field Tool command.
- Eventually the node may find a more optimal path through dynamic network evaluation.

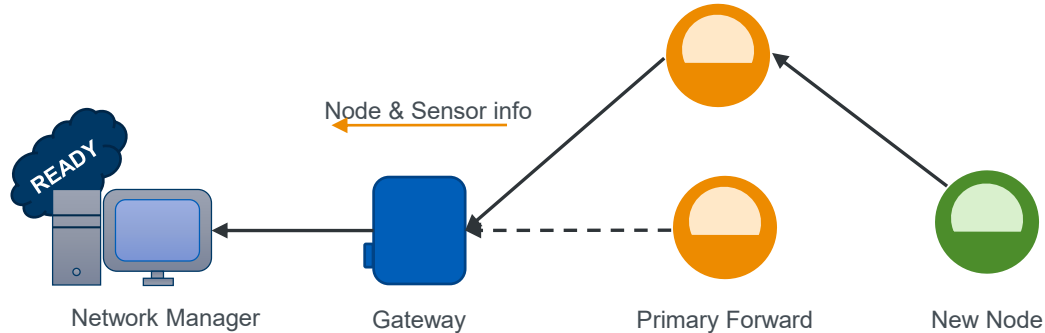

Network Segmentation

- A network is logically divided into Gateway segments
- Segmentation is represented by a unique identifier per deployed Gateway known as Color
- All nodes with the same Color form one network segment
- Segmentation distributes network load among gateways
- Overlapping segments provide network redundancy

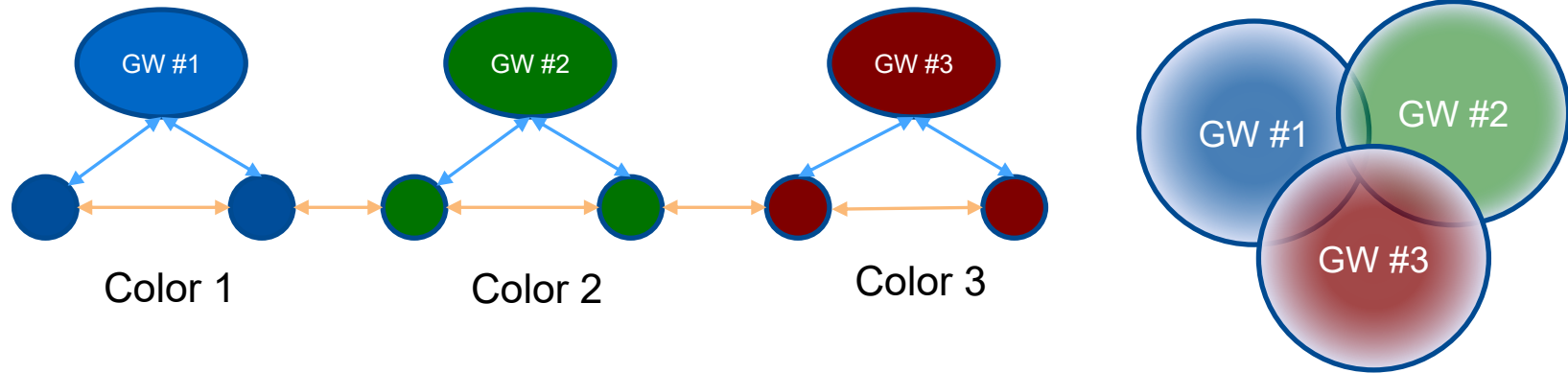

Ready Status

- Node sends discovery message after joining a network
- A node is READY when the gateway receives both the discovery message and it has a route to the gateway
- Node also sends discovery message when it switches gateways

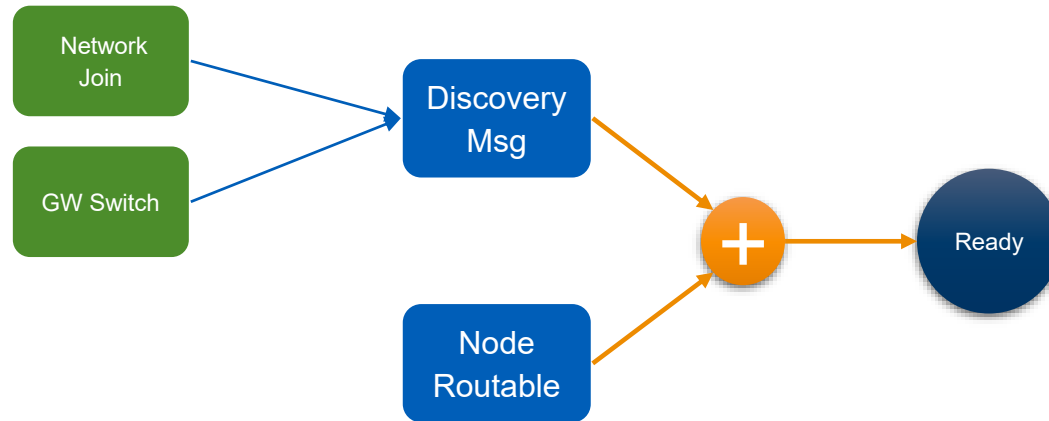

Ready Status

- Node is NOT-READY when
 - Gateway receives no route update from the node for 6 hours



Ready Status: Switching Gateways

- A node is READY under a particular gateway.
- When a node switches gateway, it sends route information to the new gateway.
- Network Manager uses the latest route to update its READY status
- The node eventually times-out at the original gateway

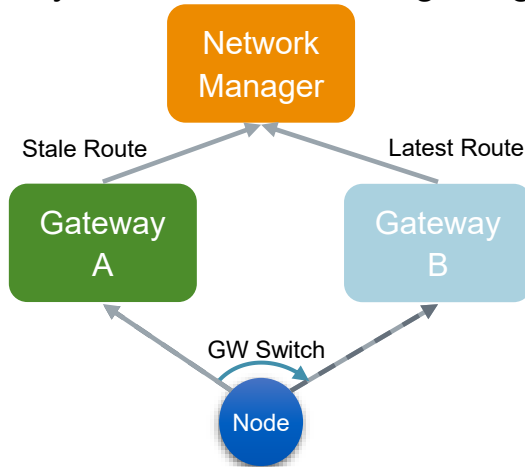

Battery Node Operation

- The battery nodes sleep except during reporting time once a day.
- Battery nodes do not take part in network formation or routing
- Always associated with an electric peer for daily reporting at a predefined 'rendezvous' schedule.
- Electric node forwards battery node data to the gateway
- Electric node generates 'proxy-discovery' message for battery node



Network Steady State Operation

Network Optimization

- Once the network is formed it goes through an optimization process
 - Network is designed to find the 'lowest cost' path to the gateway
- The nodes continue to evaluate paths.
- The essence of mesh networking:
 - Option to choose the best path
 - Multiple path redundancy = resilience

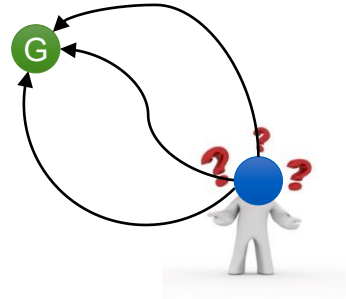

Network Optimization (cont'd)

- A node starts with a 'primary neighbor', its next-hop to the gateway.
- Path cost to the gateway is based on link quality of the hops.
 - Nodes exchange routes and gateway path costs with each other
 - Nodes evaluate link cost when they connect to their neighbors
- When a node finds a better path, it switches its 'primary'

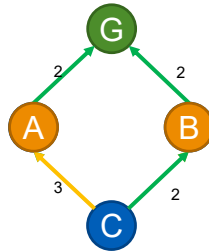

Link Cost Evaluation

- Patented RF mesh link quality measurement technique
- Node to node link quality is measured by
“Expected Transmission Count” or ETX
- Raw ETX = average retransmissions of a single frame
- Higher ETX => More retransmissions => worse link

Link Cost Evaluation

- The raw ETX is mapped in to ETX bands 1-5, aka link cost.

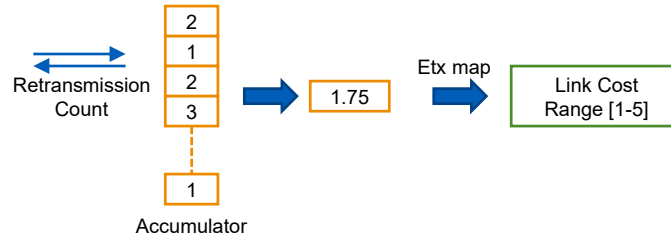

- Node's path cost = Total cost to gateway =
Normalized link cost to its primary + Primary's path cost.

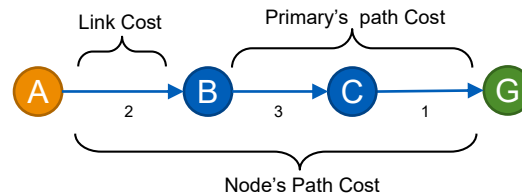

Multirate and Cost Normalization

- The link cost between node and its peer is normalized based on rate
- Lower rate = Lower Throughput = Higher Cost
- Supported rates = 1/8x, 1/4x, 1/2x, 1x, 2x
[9.6, 19.2, 38.4, 76.8, 153.6 Kbps]
- Normalization factor = rate throughput ratio

Data Rate	Data Rate (Kbps)	Throughput ratio
1/8x	9.6	1
1/4x	19.2	2.5
1/2x	38.4	5
1x	76.8	10
2x	153.6	20

Rate	Bandwidth Factor	Cost Multiplier
9.6	1	5/1=5
19.2	2.5	5/2.5=2
38.4	5	5/5=1

Rate Adaption

- Patented rate/power adaption algorithm
- The 'common control rate' is identical for the whole network
- The connection rate is adaptive
 - Higher link cost → Lower Rate
 - Lower link cost → Higher Rate

Lower rate when the link is bad

Raise rate when link is good

- The convergence is designed to maximize throughput.

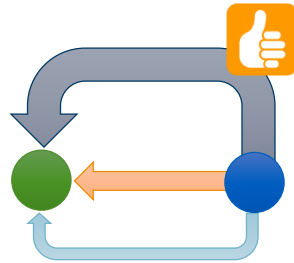

Rate Adaption

A typical sparse neighborhood configuration may look like

- MR-C := {R0 = 9.6}
- MR-E := {R0 = 9.6, R1 = 19.2, R2 = 38.4}

A dense network typically has a configuration that looks like

- MR-C := {R0 = 38.4}
- MR-E := {R0 = 38.4, R1 = 76.8, R2 = 153.6}

Power Adaption

- Power level starts with neighbor density
 - $\frac{1}{2}$ Watt for dense neighborhoods, 1 Watt for sparse.
- If a link can adapt to the highest rate, nodes will begin sampling lower power levels
- 4 power levels available (Release 9.5)
- Lower interference generally in dense areas while retaining the capacity to use higher power for longer distance when needed

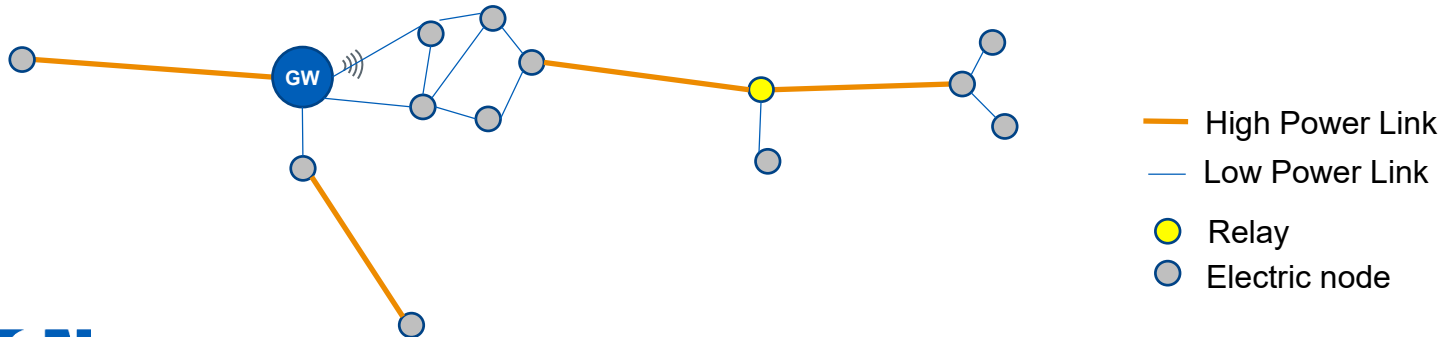

Network Redundancy

- Node maintains an alternate primary with similar cost for traffic forwarding and load balancing.

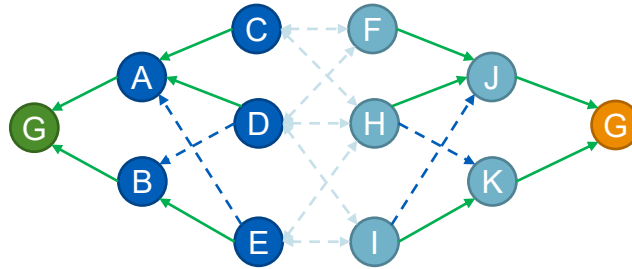

- Node maintains two sets of suitable neighbors that offer paths to current gateway and an alternate gateway.

Primary Path Failure Detection

- Node connects to its primary at least once every 2 hours.
- If connection fails, node retries (at least 25) for at least 30 minutes
- If all retry attempts fail, node declares a link failure.



Primary Path Failure: What follows

- A node switches its primary path if it:
 - Has an alternate path to the gateway.... AND
 - Detects primary path link failure.... OR
 - Receives a broadcast message from some other node informing about its primary failure

Primary Path Failure: What follows

- When node has no suitable primary or secondary to use, it broadcasts its own primary failure to alert its descendants
- The primary path failure is thus propagated hop by hop

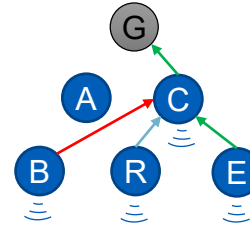
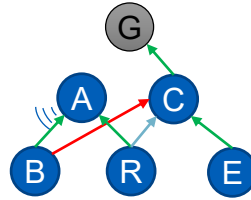
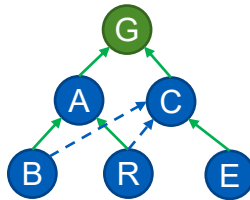

Gateway Failure: What follows

- Gateway failure information is propagated throughout the segment.
- The nodes in overlapping segments switch primaries first
- Other nodes follow hop by hop
- The whole segment gradually points to an alternate gateway within 24 hours.

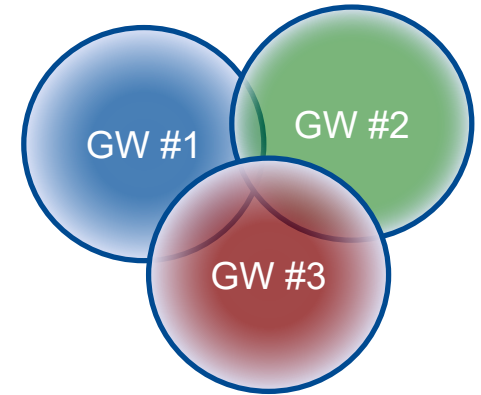
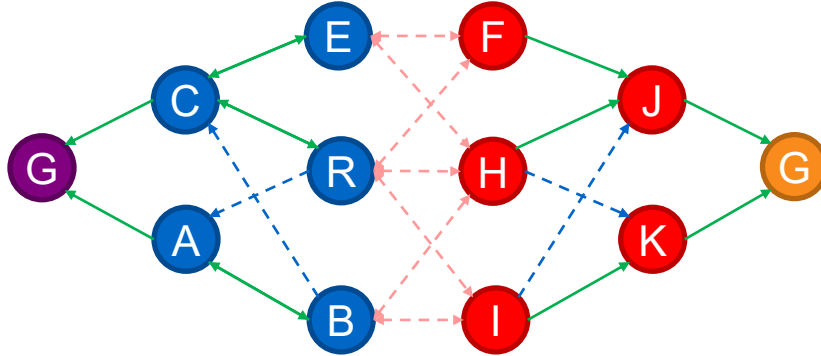

- Segment overlap is therefore essential

Battery Association Convergence

- The battery association is renewed at every rendezvous.
- If link cost > threshold, the electric node rejects the association.
- Battery node starts broadcasting again looking for a partner
- Last partner does not respond, allowing new partners to connect
- Process continues until a good link-partner is found.

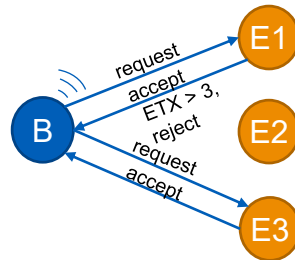

Outage and Restore: Network Response

- A node in outage can run up to 4 min on backup power
- An outage node does not participate in any connections. Except when:
 - It needs to send an outage alarm
 - Incoming connection is carrying an outage alarm

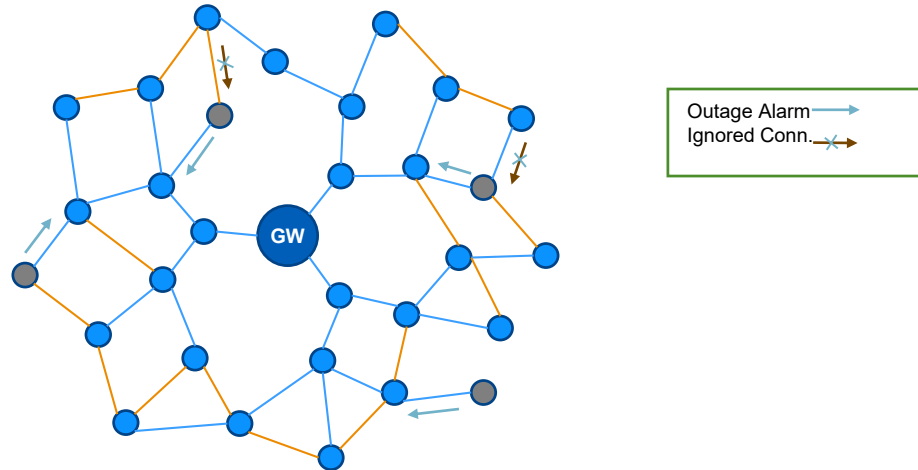

Outage Delivery

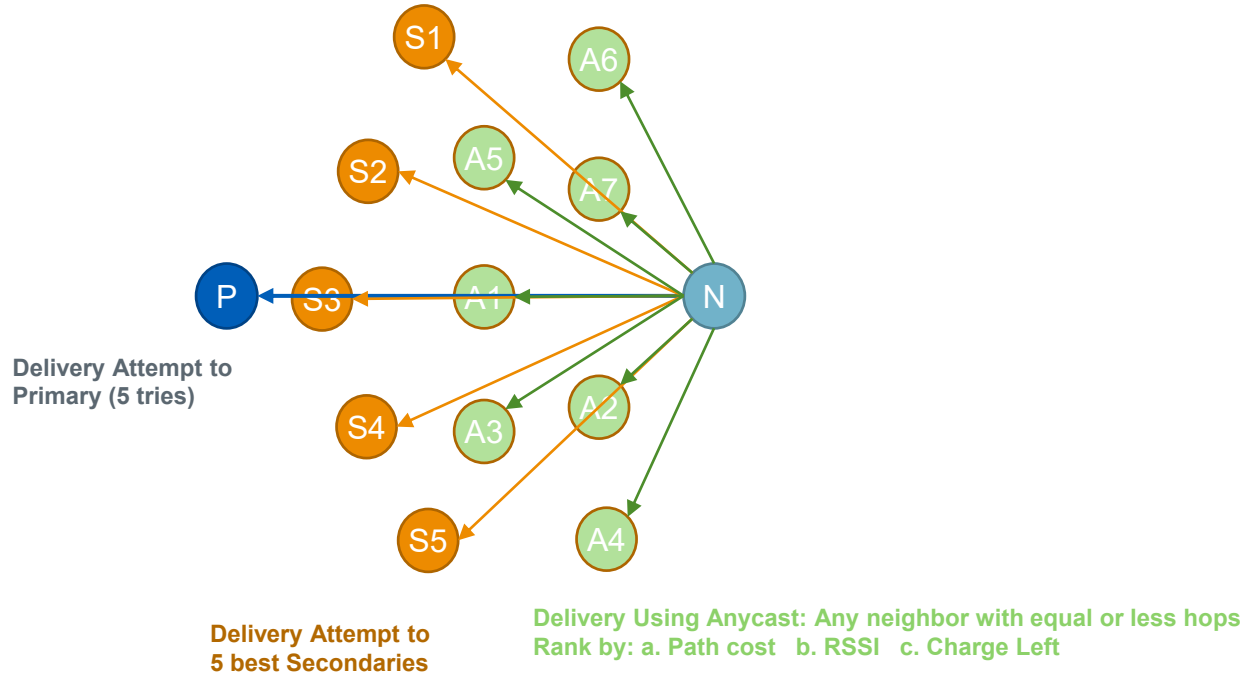

Outage and Restore: Network Response

- Large scale outage event -> alarms not guaranteed to reach GW
- Outage alarm delivery improvements:
 - Aggregate outage alarms prior to sending its own
 - Connect only when outage alarm message is to be delivered
 - Employ connection back-off at the powered node, when it receives an outage message

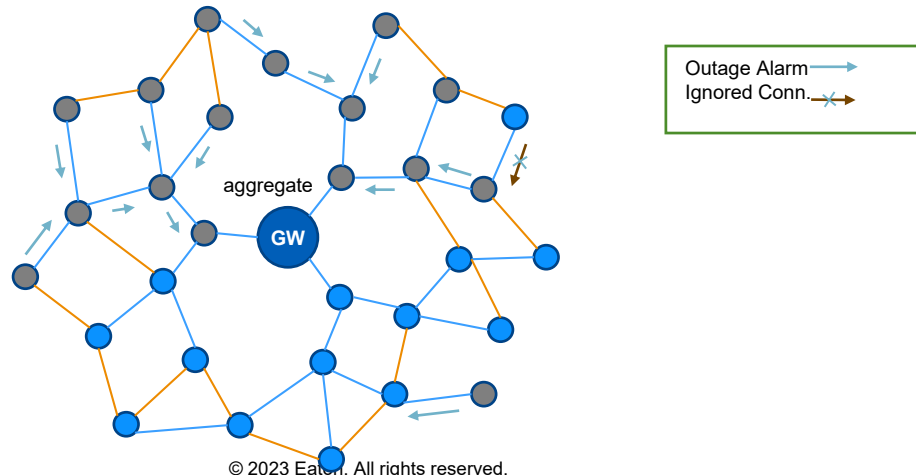

Outage and Restore: Network Response

Outage Response is constrained by Network Topology

- A single node or relay carrying a lot of descendants may reduce chance.
- A message has less probability of reaching gateway if it originates many hops away

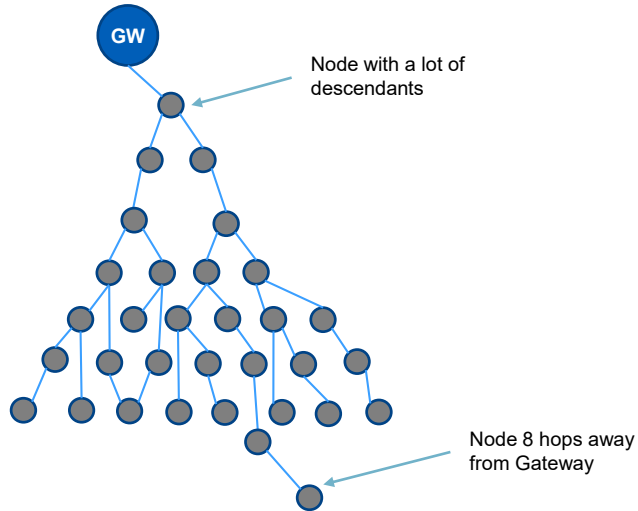
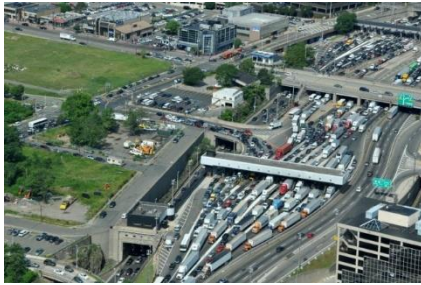

New/Recent Features (Release 9.3-9.7)

- WiFi IPLink Meter (9.3)
 - Acts as network bridge for the RF Network to utility backhaul using WiFi
 - Based on the C2SX meter
- Power Adaptation (9.5)
- Remote Meter Programming
 - Supports meter configuration for Elster A3 and LG S4
- Gas Meter (9.7)



QUESTIONS?

Copyright 2004 by Randy Glasbergen.
www.glasbergen.com



“I had to quit drinking coffee. It keeps me awake during presentations.”



Powering Business Worldwide

© 2023 Eaton. All rights reserved.

Eaton RF Mesh Network Troubleshooting

RF Network Troubleshooting

- Yukon has added features to display Network Information.
- If provided with GPS Coordinates, Yukon also provides mapping of the network topology overlaid on the physical location.

Peak Demand: 0.000 kW 04/30/2023 02:00:00
Demand: 0.000 kW 04/30/2023 02:00:00
Voltage: 240.1 Volts 04/30/2023 02:00:00

Archived Usage Data [HTML](#) | [CSV](#)
Daily Usage Data [HTML](#) | [CSV](#)

View All | Quick View

Network Information

Battery Node Associations:	0
Boot Loader Version:	2
Comm Status:	Ready
Comm Status Obtained At:	05/01/2023 00:17
Groups:	915rollback-gw211
Hardware Version:	RFN420CL
Hop Count:	1
Joined Network At:	05/27/2022 10:06
MAC Address:	00:14:08:04:DE:40
Neighbor Count:	12
Node Firmware Version:	R11.5.11.S1Kp
Node Serial Number:	4210031347
Node Type:	Electric node
Primary Forward:	GW211
Primary Neighbor:	00:14:08:09:65:08
Primary Neighbor Data Timestamp:	04/29/2023 23:59
Primary Neighbor Link Cost:	1.0
Product Number:	RFN420CL
Reverse Lookup:	GW211

Show All

Notes

Note Text (255 characters max)

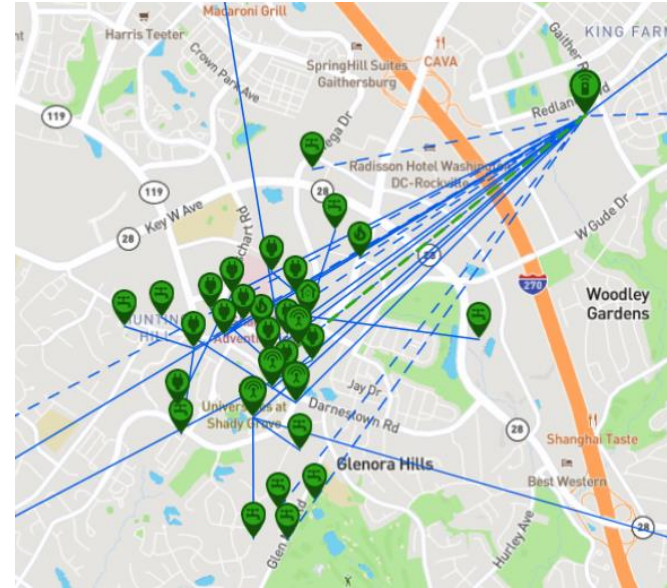

RF Network Troubleshooting

- Node Details screen gives a lot of information about the node (Node S/N, fw version, comms status, link cost, power, data rate...)

Network Manager Welcome Administrator | Log out

Gateway Node Primary Gateway GW223 GO

Node Details

INFO [Menu Options](#)

Node Serial Number : 421000058
Node Type : Electric node
Sensor Info : 88638034 (ITRN , C25X) [2/2/2016 00:08:00]
Product Number : RFN420CL
Hardware Version : RFN420CL
Software Version : R9.0.0.S1Kp
Node Names :
Groups : Next Gen 2 Water Packet-9.6, All_7.0_Nodes, 9.6 Meters
Commissioned ? : Yes
Commissioned Time :
In Network ? : Yes
In Network Time : 2/2/2016 00:08:00

NODE VERSIONS
Backup Eka Software Version : Q9.0.0.28Kp

COMMUNICATIONS
Node Address : 00:14:08:00:00:11
Primary Gateway : **GW221**
Communication Status : Ready
Communication Status obtained at : 10/21/2016 17:50:06
Number of Hops to Gateway : 1
Current Number of Neighbors : 11
Current Primary Neighbor : **00:14:08:08:84:A8 (Gateway 10106171221)**
Link Cost to Primary Neighbor : 1.0 (ETX band: 1)
Current Link Rate to Primary Neighbor : 1/2x
Current Link Power to Primary Neighbor : 1 Watt
Current Neighbor Data Timestamp : 10/21/2016 07:21:30

DATA COLLECTION CONFIGURATION

Row	Channel Number	Units	Enabled ?	Recording Frequency	Reporting Frequency
1	1	Wh Quadrant 1, Quadrant 4	Yes	1 hr	1 day
2	2	Wh Quadrant 2, Quadrant 3	No	1 hr	1 day
3	3	Wh Quadrant 2, Quadrant 3, Quadrant 4, Quadrant 1	Yes	1 hr	1 day

100 m
500 ft

Click [here](#) to update node location.

Tiles Courtesy of MapQuest
Data by OpenStreetMap, under CC BY SA

Messages



Powering Business Worldwide

RF Network Troubleshooting: Neighbors

Gateways		Search Results		Search Results		Neighbors	
Row	Data Timestamp	Neighbor Address	Link Cost	ETX Band	Current Rate	Current Power	
[-] 411000028							
1	4/29/2014 15:51:16	00:14:08:03:80:38	1.2	2	1x	0.5 Watt	
2	4/29/2014 15:51:16	00:14:08:04:B6:6B	1.0	2	1x	0.5 Watt	
3	4/29/2014 15:51:16	00:14:08:04:08:60	1.0	2	1/2x	0.5 Watt	
4	4/29/2014 15:51:16	00:14:08:04:5E:D1	1.0	2	1/2x	0.5 Watt	
5	4/29/2014 15:51:16	00:14:08:04:03:58	1.0	2	1/2x	0.5 Watt	
6	4/29/2014 15:51:16	00:14:08:01:DB:E7	1.0	2	1/2x	0.5 Watt	
7	4/29/2014 15:51:16	00:14:08:04:60:19	1.0	2	1/2x	0.5 Watt	
8	4/29/2014 15:51:16	00:14:08:03:4C:5F	1.0	2	1/2x	0.5 Watt	
9	4/29/2014 15:51:16	00:14:08:06:4A:70	1.0	2	1x	0.5 Watt	
10	4/29/2014 15:51:16	00:14:08:04:00:95	1.0	2	1/2x	0.5 Watt	
11	4/29/2014 15:51:16	00:14:08:03:4C:B3	1.0	2	1/2x	0.5 Watt	
12	4/29/2014 15:51:16	00:14:08:02:3F:F3	1.0	2	1/2x	0.5 Watt	
13	4/29/2014 15:51:16	00:14:08:05:30:02	1.0	2	1x	0.5 Watt	
14	4/29/2014 15:51:16	00:14:08:03:4C:67	1.0	2	1/2x	0.5 Watt	
15	4/29/2014 15:51:16	00:14:08:03:5E:84	1.0	2	1/2x	0.5 Watt	
16	4/29/2014 15:51:16	00:14:08:03:5F:A5	1.0	2	1x	0.5 Watt	
17	4/29/2014 15:51:16	00:14:08:04:03:EC	1.0	2	1/2x	0.5 Watt	
18	4/29/2014 15:51:16	00:14:08:04:1A:98	1.0	2	1/2x	0.5 Watt	
19	4/29/2014 15:51:16	00:14:08:01:D2:E5	1.0	2	1/2x	0.5 Watt	
20	4/29/2014 15:51:16	00:14:08:01:49:18	1.0	2	1x	0.5 Watt	
21	4/29/2014 15:51:16	00:14:08:05:2F:F9	3.6	2	1x	0.5 Watt	
22	4/29/2014 15:51:16	00:14:08:03:5E:8D	1.0	2	1/2x	0.5 Watt	
23	4/29/2014 15:51:16	00:14:08:03:46:BA	1.0	2	1/2x	0.5 Watt	
24	4/29/2014 15:51:16	00:14:08:03:47:CA	1.0	2	1/2x	0.5 Watt	
25	4/29/2014 15:51:16	00:14:08:01:49:11	3.6	2	1x	0.5 Watt	
26	4/29/2014 15:51:16	00:14:08:03:E2:A5	1.0	2	1x	0.5 Watt	
27	4/29/2014 15:51:16	00:14:08:01:96:22	1.0	1	1x	0.5 Watt	
28	4/29/2014 15:51:16	00:14:08:05:30:00	1.0	2	1x	0.5 Watt	
29	4/29/2014 15:51:16	00:14:08:04:50:17	1.0	2	1/2x	0.5 Watt	
30	4/29/2014 15:51:16	00:14:08:03:44:62	1.0	1	1x	0.5 Watt	



RF Network Troubleshooting: Routes

Row	Data Timestamp	Dest. Address	Next Hop Address	Hop Count	Cost	Flags
40	4/8/2014 22:33:52	00:14:08:03:5F:A5	00:14:08:03:5F:A5	1	2	PF,VR
41	4/8/2014 02:26:33	00:14:08:03:5F:A5	00:14:08:03:5F:A5	1	2	PF,VR
42	4/7/2014 22:32:04	00:14:08:03:5F:A5	00:14:08:03:5F:A5	1	2	PF,VR
43	4/7/2014 02:27:27	00:14:08:03:5F:A5	00:14:08:03:5F:A5	1	2	PF,VR
44	4/6/2014 22:31:05	00:14:08:03:5F:A5	00:14:08:03:5F:A5	1	2	PF,VR
45	4/6/2014 02:33:04	00:14:08:03:5F:A5	00:14:08:03:5F:A5	1	1	PF,VR
46	4/5/2014 22:31:32	00:14:08:03:5F:A5	00:14:08:03:5F:A5	1	1	PF,VR
47	4/5/2014 02:24:53	00:14:08:03:44:62	00:14:08:03:44:62	1	2	PF,VR
48	4/4/2014 22:29:43	00:14:08:03:44:62	00:14:08:03:44:62	1	2	PF,VR
49	4/4/2014 02:29:10	00:14:08:03:44:62	00:14:08:03:44:62	1	2	PF,VR
50	4/3/2014 22:34:08	00:14:08:03:44:62	00:14:08:03:44:62	1	2	PF,VR
51	4/3/2014 02:24:24	00:14:08:03:44:62	00:14:08:03:44:62	1	2	PF,VR
52	4/2/2014 22:34:45	00:14:08:03:44:62	00:14:08:03:44:62	1	2	PF,VR
53	4/2/2014 02:23:17	00:14:08:03:44:62	00:14:08:03:44:62	1	2	PF,VR
54	4/1/2014 22:26:40	00:14:08:03:44:62	00:14:08:03:44:62	1	2	PF,VR
55	4/1/2014 02:22:53	00:14:08:03:44:62	00:14:08:03:44:62	1	2	PF,VR

RF Network Troubleshooting

Issue: Meter not joining the network

- Multiple step process:
 1. Perform a current meter reading Over The Air (OTA) using Field Tool to verify the meter is individually operational
 2. Retrieve neighbor table of node using Field Tool
 3. Check if this node appears as a neighbor of a nearby node that's already in the network. If not go to Step 6
 4. Verify ETX Band for this node at all neighbors
 5. If ETX Band is 4 or above with all neighbors, go to Step 6
 6. Reinforce infrastructure for this node

RF Network Troubleshooting

Issue: Node reporting Communications Status “Not Ready”

- Backhaul connection may be down
- Not Ready may be a temporary condition because a node is in the process of switching to a new Gateway OR a firmware upgrade is in progress
- If node continues to be Not Ready for 24 hours or more:
 - Check Node logs:
 - If data reports are being sent, node is able to communicate with its neighbors
 - Original route to Gateway is reforming or has an issue

RF Network Troubleshooting

- Node logs

Yukon®
Network Manager

Network Manager Welcome Administrator | Log out

Gateway Node Select one Enter search detail... GO

Gateway Details Logs Nodes Node Details Nodes Logs

Navigation Menu Dashboard Network Manager Info Gateways [16] Gateway Groups [1] Nodes [292] Node Groups [18] Report Schedules [1] Reports

Row	Log Timestamp	Log
4300000310		
1	10/20/2016 15:54:54	Updated formatID 1281 index for node 4300000310: StartSeq 3850, EndSeq 3850
2	10/20/2016 15:54:54	Received formatID 1281 report from node 4300000310: StartSeq 3850, EndSeq 3850
3	10/20/2016 13:54:43	Updated formatID 1281 index for node 4300000310: StartSeq 3849, EndSeq 3849
4	10/20/2016 13:54:43	Received formatID 1281 report from node 4300000310: StartSeq 3849, EndSeq 3849
5	10/20/2016 11:54:44	Updated formatID 1281 index for node 4300000310: StartSeq 3848, EndSeq 3848
6	10/20/2016 11:54:44	Received formatID 1281 report from node 4300000310: StartSeq 3848, EndSeq 3848
7	10/20/2016 09:54:44	Updated formatID 1281 index for node 4300000310: StartSeq 3847, EndSeq 3847
8	10/20/2016 09:54:44	Received formatID 1281 report from node 4300000310: StartSeq 3847, EndSeq 3847
9	10/20/2016 07:54:44	Updated formatID 1281 index for node 4300000310: StartSeq 3846, EndSeq 3846
10	10/20/2016 07:54:44	Received formatID 1281 report from node 4300000310: StartSeq 3846, EndSeq 3846
11	10/20/2016 06:25:56	Received routing table from 4300000310: StartSeq 3845, EndSeq 3845
12	10/20/2016 06:25:55	Requested routing table for 4300000310
13	10/20/2016 06:19:59	Received visibility table from 4300000310
14	10/20/2016 06:19:58	Received neighbor table from 4300000310
15	10/20/2016 06:19:55	Requested visibility table for 4300000310
16	10/20/2016 06:19:55	Requested neighbor table for 4300000310
17	10/20/2016 05:54:44	Updated formatID 1281 index for node 4300000310: StartSeq 3845, EndSeq 3845
18	10/20/2016 05:54:44	Received formatID 1281 report from node 4300000310: StartSeq 3845, EndSeq 3845
19	10/20/2016 03:54:45	Updated formatID 1281 index for node 4300000310: StartSeq 3842, EndSeq 3844
20	10/20/2016 03:54:45	Received formatID 1281 report from node 4300000310: StartSeq 3842, EndSeq 3844
21	10/20/2016 01:54:44	Updated formatID 1281 index for node 4300000310: StartSeq 3841, EndSeq 3841
22	10/20/2016 01:54:44	Received formatID 1281 report from node 4300000310: StartSeq 3841, EndSeq 3841
23	10/19/2016 23:54:48	Updated formatID 1281 index for node 4300000310: StartSeq 3840, EndSeq 3840
24	10/19/2016 23:54:48	Received formatID 1281 report from node 4300000310: StartSeq 3840, EndSeq 3840
25	10/19/2016 21:54:44	Updated formatID 1281 index for node 4300000310: StartSeq 3839, EndSeq 3839
26	10/19/2016 21:54:44	Received formatID 1281 report from node 4300000310: StartSeq 3839, EndSeq 3839
27	10/19/2016 19:54:47	Updated formatID 1281 index for node 4300000310: StartSeq 3836, EndSeq 3838
28	10/19/2016 19:54:47	Received formatID 1281 report from node 4300000310: StartSeq 3836, EndSeq 3838
29	10/19/2016 17:54:46	Updated formatID 1281 index for node 4300000310: StartSeq 3835, EndSeq 3835
30	10/19/2016 17:54:46	Received formatID 1281 report from node 4300000310: StartSeq 3835, EndSeq 3835

RF Network Troubleshooting

Issue: Node reporting Communications Status “Not Ready”

- If there are no data reports from the node for 3 days:
 - Check Routing table of Node to determine last known Primary Forward Node
 - Locate the Primary Forward in the node’s neighbor table and check its link cost.
 - Review the link cost history of this node in the Primary Forward node’s neighbor table
 - If the link cost has degraded, the node may be in the process of switching to another Primary Forward.
 - Review the problem node’s neighbor table to verify link costs with other neighbors
 - If all neighbors have degraded link cost, visit the node to verify OTA with Field Tool

RF Network Troubleshooting

Issue: Node data intervals not received

- Nodes report their interval data periodically (usually every 24 hours) with each Interval Record (usually 15 minutes)
- Data points can be seen from the Network Manager Node Details -> Data Points for a selectable date range
- If the node is in “Ready” state and interval data is received with missing dates (i.e. gaps)
 - Network may be busy and RFN Gateway may be gap filling. It will catch up and fill the missing intervals

RF Network Troubleshooting

Issue: Node data intervals not received (cont'd)

- If the node is in “Ready” state and no reports are received for more than several days then it should be diagnosed for other root causes:
 - Check the NTP configuration at the Gateway. Nodes will not report interval data if they haven't received time sync from the gateway
 - RF Network manager and gateway communications can be checked from NM
- If the node is in “Not Ready” state then diagnose the “Not Ready” cause

RF Network Troubleshooting

Issue: All of the above (Node not joining, NOT-READY, missing data)

- Check if Gateways are running within capacity
 1. From NM, list nodes under the a gateway and verify that the total number of nodes is not too close to its maximum capacity (configured parameter during deployment. Ask Customer Service for your network's setting)
 2. Gateway logs in NM having too many entries of 'Received Message from Unknown Node' – is another indication of Gateway running out of capacity
 3. If gateway capacity issue is verified, evaluate infrastructure, and decide on gateway addition or relocation.

RF Network Troubleshooting

- Node list under a gateway

Yukon®
Network Manager

Network Manager Welcome Administrator | Log out

Gateway Node Select one Enter search detail...

Node Details Logs Logs Gateways Gateway Details

Navigation Menu

- Dashboard
- Network Manager Info
- Gateways [16]
- Gateway Groups [1]
- Nodes [292]
- Node Groups [18]
- Report Schedules [1]
- Reports

Groups :
Route Color : 3

COMMUNICATIONS

Connection Type : TCP/IP
IP Addresses : 10.106.171.206 Port: 32030 EkaNet (TCP + SSL)
Connection Status : (Connected)
Communication Status : Last connected at: 10/20/2016 13:41:38
Radios : EkaNet 915 MHz MAC Address: 00:14:08:03:E2:AB [10/13/2016 15:41:12]

Gateway location is not set. Click [here](#) to set gateway location.

GATEWAY NODE SUMMARY

Row	Data Type	Value
1	Total Nodes	6
2	Total Ready Nodes	4
3	Total Not Ready Nodes	2
4	Total Nodes With SN	4
5	Total Nodes With Info	4
6	Total Nodes Without Info	2

SERVER DATA COLLECTION SCHEDULE

Row	Data Type	Collection Schedule
1	Sensor data	4 45 */1 * * * *
2	Node logs	4 45 */1 * * * *
3	Gateway logs	4 45 */1 * * * *
4	Node parameter data (routing, neighbors, statistics)	4 45 */1 * * * *
5	Node alarms	4 45 */1 * * * *
6	General Purpose data	4 45 */1 * * * *

GATEWAY DATA SEQUENCE NUMBERS

Data Completeness Status : (High Percentage)

Applications

Firmware Upgrade

- RF system can deliver new features for all RF devices through firmware upgrades
- All RF upgrade images are created with a RSA signature and authenticated before being accepted by a node
- Firmware upgrade mechanism relies on neighbor topology to “spread” the new images down and across the network
- The upgrade mechanism is capable of upgrading any RF node unless it has poor link connectivity to the network
- New design facilitates traffic efficient upgrades resulting in minimizing effect to network traffic

Firmware Upgrade – Gateway

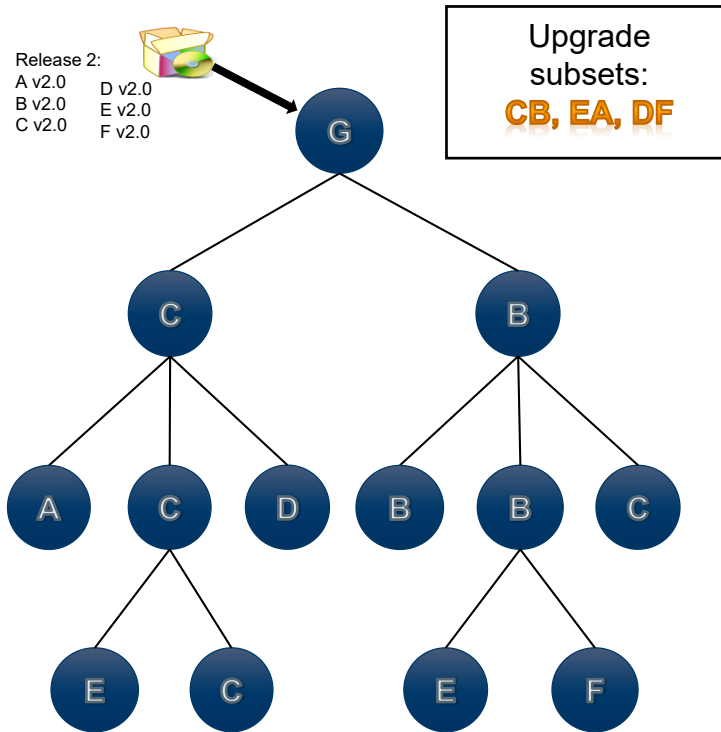

- Upgrades are initiated at the Gateway
- Controlled traffic event
- Gateway sends only a subset of all images into network at anytime
- A defined period of time is given for images to propagate into the network
- Nodes apply updates and send version information to Gateway
- Gateways stop sending images when 99% of nodes have been updated or the defined period of time has elapsed
- Nodes will continue to upgrade each other as needed

Firmware Upgrade – Node Upgrade

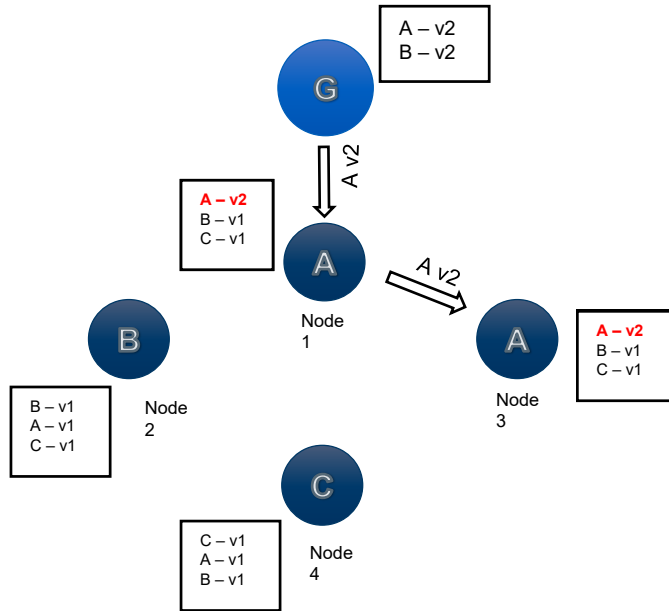

- A node receives new firmware from one of its neighbors
- Neighbors connect to each other periodically to send application traffic or to exchange control traffic
- Firmware exchanges are randomized to avoid heavy network traffic: 1/6 – Gateway, 1/3 - Nodes
- All Nodes store their own and images of 2 other types of nodes to facilitate faster spread through the network
- A node will send the newer version of any of its stored firmware to its neighbor

Firmware Upgrade – Node Upgrade

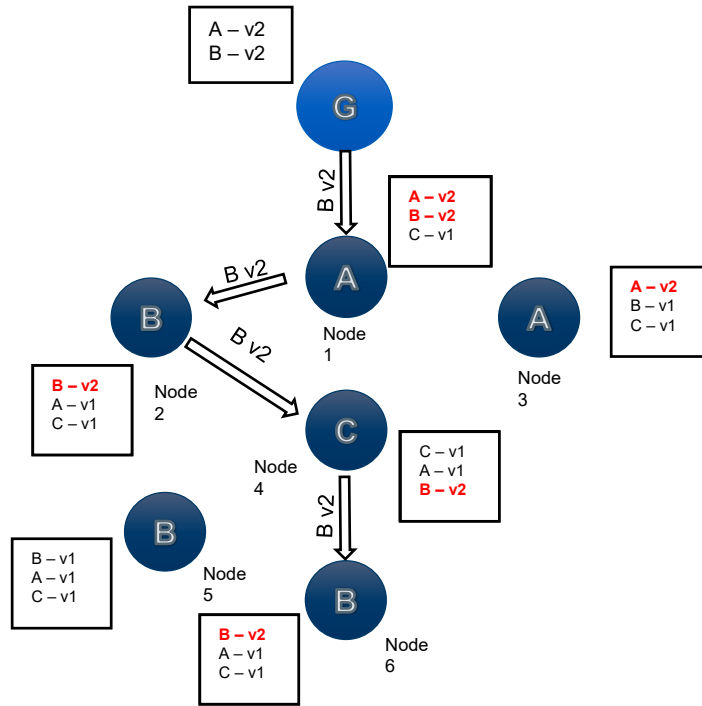

- Nodes of different types can send an upgrade to each other from their stored images
- Nodes send updated firmware version to the Gateway
- A node that gets newly installed will receive updated firmware if its available from one of its neighbors

Outage Detection

- RFN Outage and Blink Determination
 - Blink is defined as loss or restoration of power for less than 10 seconds (Release 9.0)
 - Outage is loss of power for 10 or more seconds
 - Restore is after power has been back on for 60 seconds or more

Outage Detection

Outage Detection and Reporting Steps

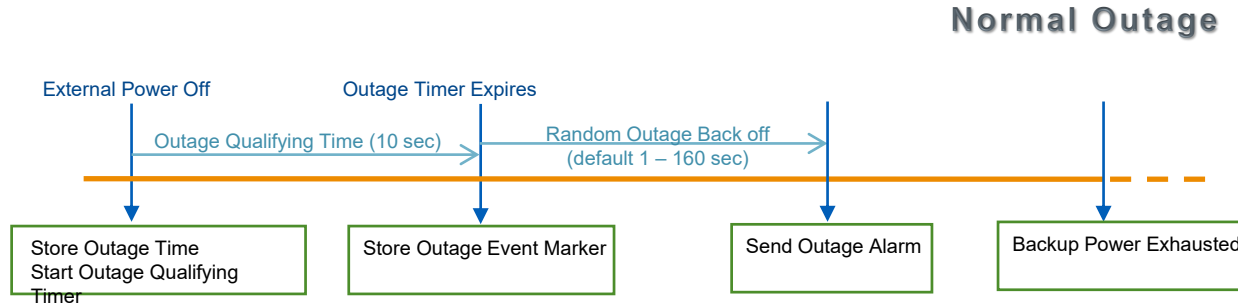
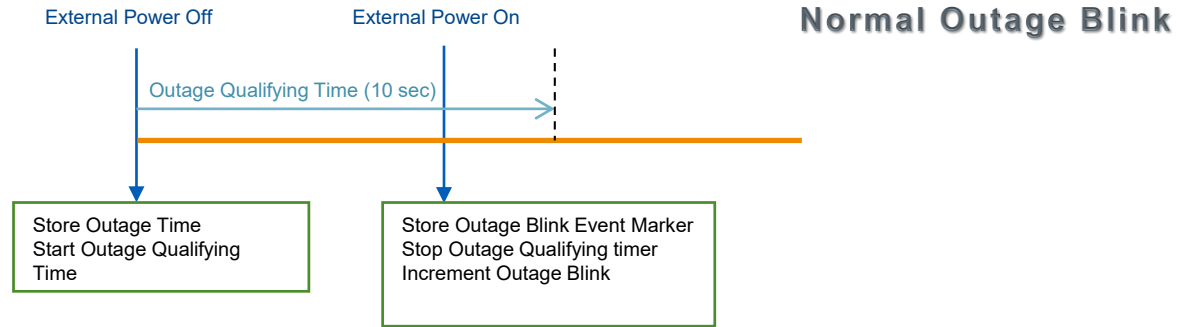

Outage Detection

Restoration Reporting Steps

Normal Restore

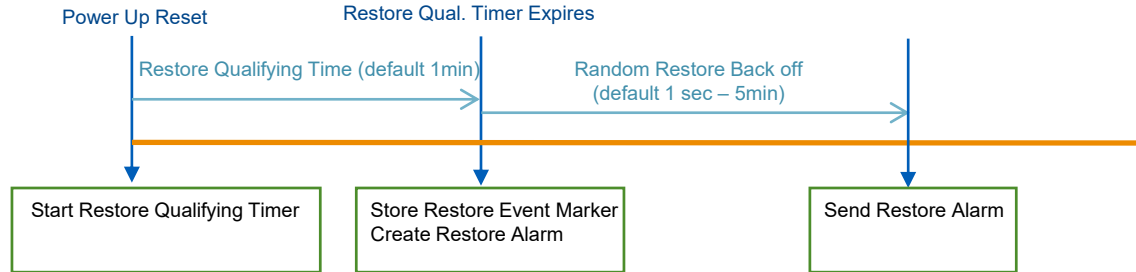

RFN Broadcast Summary

- RFN Broadcast is a controlled flooding mechanism where the message frames are repeatedly broadcast from node to node
- Uses the link layer and it works independent of the network routing connectivity
- Limits the number of broadcasts as well as the period of transmission in order to reduce the impact on any unicast messaging
- Supports authentication and data encryption as well as delay and replay protection
- Uses security keys independent of the unicast transmission
- Supports real-time and non-real time delivery

Broadcast (Real-time message delivery)

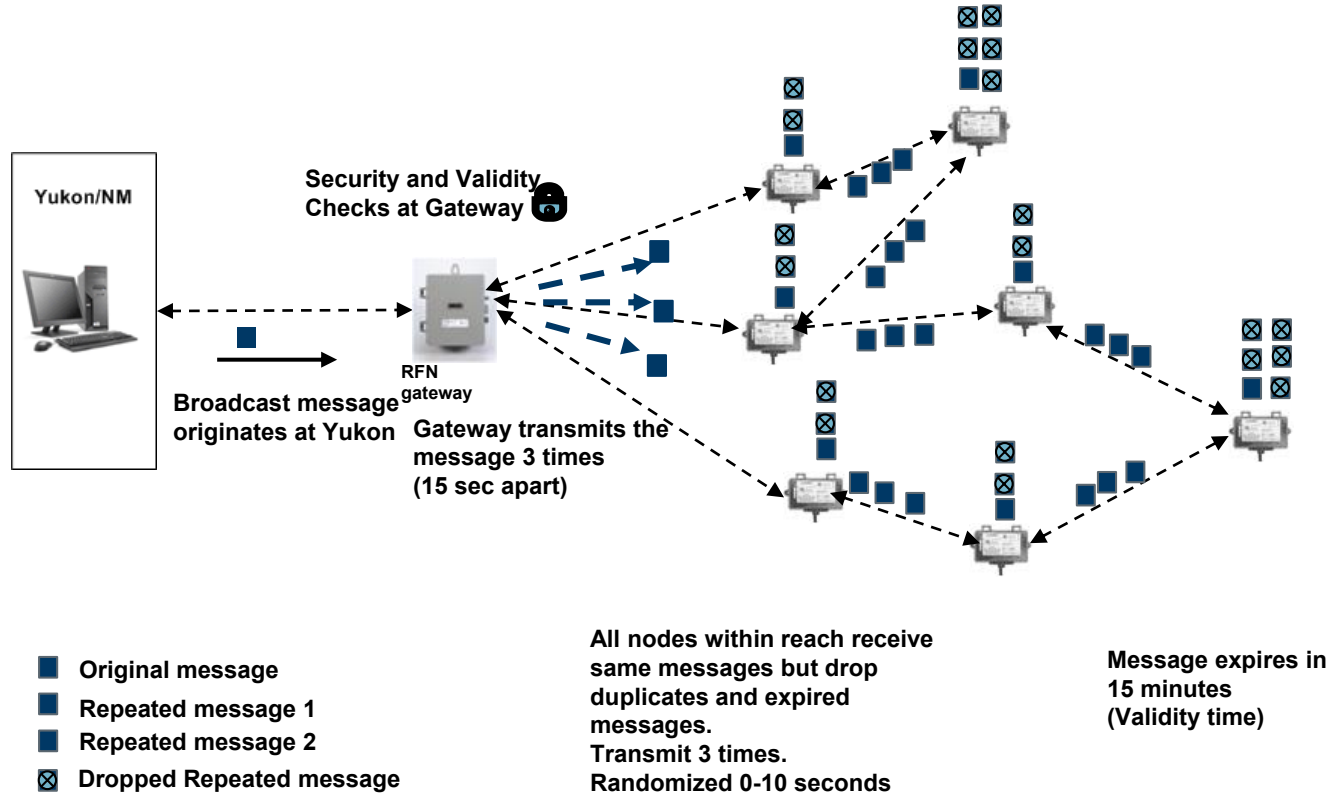

RFN Broadcast Summary

- Supports mainly Demand Response (DR) application. DR messages are broadcast as real-time/high-priority messages
- Originates at the Yukon DR Application
- NM implements flow control into the network
- RFN Gateways and Nodes implement message security, validity time and priority as the messages pass onwards into the RF mesh network

RFN Data Streaming

- Near-real time monitoring of selected meter data mainly aimed for voltages but supports other meter data points (KW, VA, VAR)
- Uses a new RFN connectionless transport layer messaging with low latency, shorter data payloads. Supports up to 8 data points per message. Not recorded nor gap filled.
- Security and validity checks at each node and the gateway
- 1, 3, 5, 15 and 30 minute configurable reporting intervals
- End-to-end configuration and management and data interface to the customer management system are provided by Yukon
- Capacity is managed by Yukon and allows data streaming on a subset of meters.

RFN Data Streaming

- Yukon enables and select channels for Data Streaming
- Nodes start reporting data

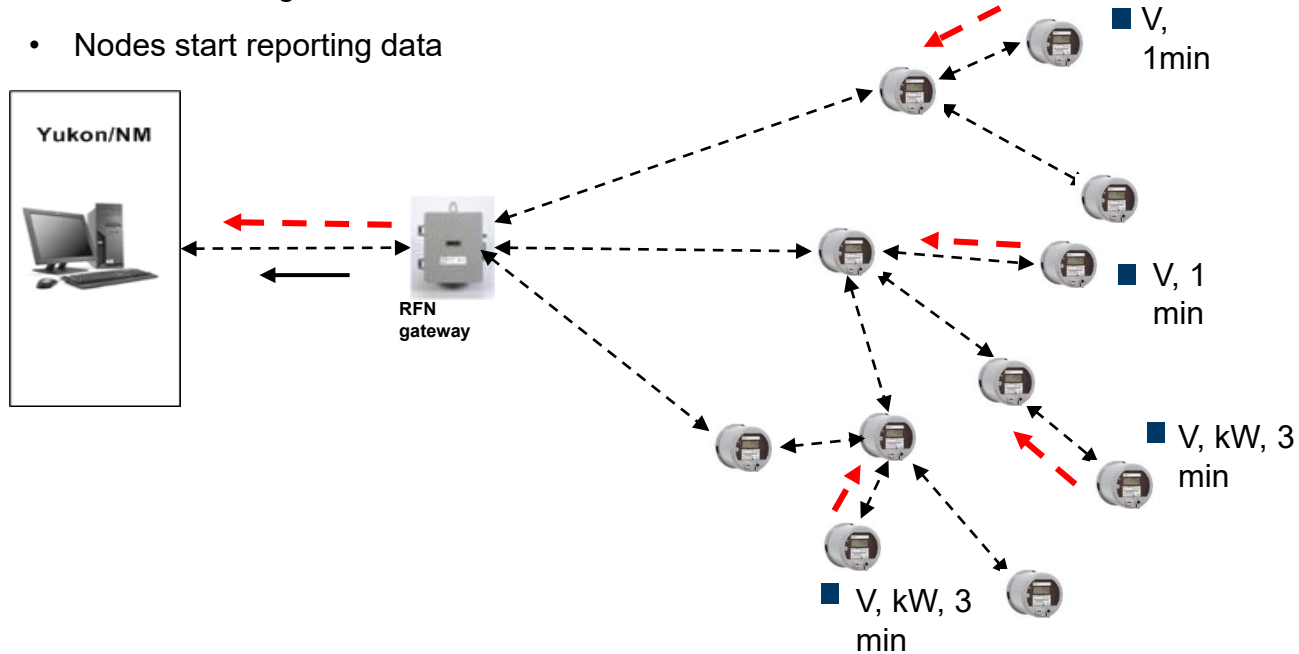

Data Streaming: Yukon Configuration

☆ Configure Data Streaming

Configure Data Streaming:

Devices Selected: **5** temporary collection 

Note: Select the data streaming configuration you wish to start using

Configuration Type:

Interval (in minutes): 

Attributes

Channels have to be enabled in the meter in order to stream

Delivered kWh:

Demand:

Received kWh:

Voltage:

☆ GW224

Gateway Information

Name: GW224
Serial No: 10106171224
Hardware Version: GW2.0
Software Version: R_8_1_1
Upper Stack Version: R_8_1_1_0_2
Radio Version: R4.2.0qp
Release Version: 8.1.2
Version Conflicts: None
Application Mode: Normal
Streaming Capacity: **15.01%** [View History](#)

Data Streaming: Yukon Configuration



Powering Business Worldwide

[AMI](#) ▾ | [Demand Response](#) ▾ | [Volt/Var](#) ▾ | [Assets](#) ▾ | [Tools](#) ▾ | [Admin](#) ▾

[Home](#) / [Data Streaming Configurations](#)

☆ Data Streaming Configurations

Attributes ▲

Average Voltage (Phase A), Delivered kWh, Received kWh, Sum kVAh, Sum kVArh, Voltage (Phase A), Voltage (Phase B), Voltage (Phase C)

Delivered kVA, Delivered kWh, Demand, Voltage (Phase A), Voltage (Phase B), Voltage (Phase C)

Delivered kWh	15 minutes	1
Delivered kWh, Demand, Power Factor, Voltage (Phase A)	1 minute	1
Delivered kWh, Demand, Received kWh, Voltage	5 minutes	2
Delivered kWh, Demand, Received kWh, Voltage	5 minutes	1
Delivered kWh, Demand, Received kWh, Voltage	30 minutes	1
Delivered kWh, Demand, Received kWh, Voltage	5 minutes	1
Delivered kWh, Demand, Received kWh, Voltage	5 minutes	1
Delivered kWh, Demand, Received kWh, Voltage	1 minute	1
Delivered kWh, Demand, Received kWh, Voltage	5 minutes	1
Delivered kWh, Demand, Received kWh, Voltage	1 minute	1
Delivered kWh, Received kWh, Voltage (Phase A), Voltage (Phase B), Voltage (Phase C)	1 minute	1

Actions ▾

- Data Streaming Summary
- Data Streaming Discrepancies
- Collection Actions
- Configure Other Devices

On-Demand Reads

- On-Demand reads (current meter reading) can be initiated from Yukon/NM to a node
- Average time is about 2-3 seconds per hop but it can be more depending on many factors
 - How busy the gateway and nodes are at the time of on-demand
 - Link quality
 - Data Rate

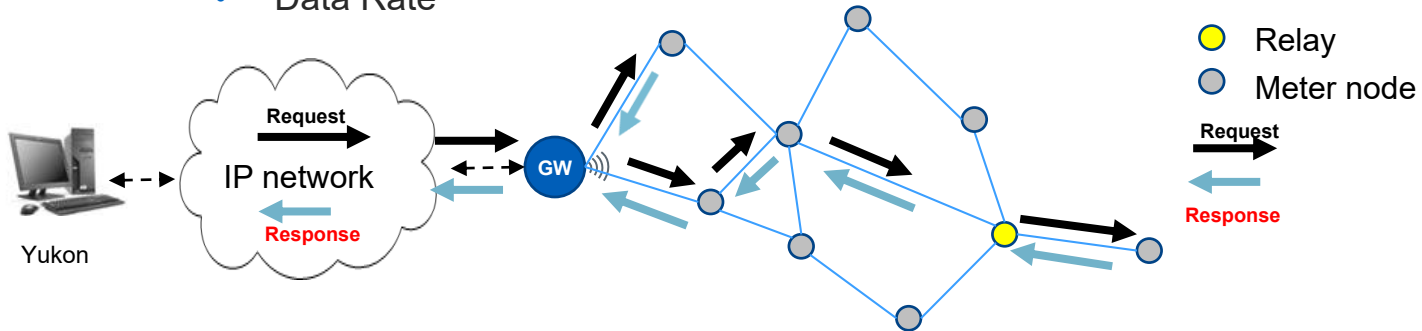

Q & A

- Questions?

Support Slides

Acronyms

AMI Advanced Metering Infrastructure	OS Operating System
APN Access Point Name	OTA Over The Air
DA Distribution Automation	PLC Power Line Carrier
DR Demand Response	QoS Quality of Service
ETX Expected Transmission Count	RF Radio Frequency
E2E End-to-End	SG Smart Grid
EV-DO Evolution Data Optimized	RFN RF Network
HSPA High Speed Packet Access	TCP Transmission Control Protocol
GW Gateway	UDP User Datagram Protocol
IP Internet Protocol	
LCR Load Control Relay	
M&C Monitoring and Control	

RFN Gateway



- Network Bridge between RF wireless mesh and IP wide area network
- Automatic RF mesh node registration and discovery
- Temporary repository and gap filling for delayed or missed mesh network data for reliable communications
- RF mesh network time synchronization
- RF mesh node firmware upgrade management
- Secure SSL communications
- Wired and wireless backhaul support
 - 10/100 Ethernet
- Onboard backup power for Outage
- Optional enclosure with UPS

RFN Electric Nodes

- AMI: Landis+Gyr, Itron, Sentinel, Elster (and others)



- Demand Response: LCR-6200, LCR-6600, LCR-6700



- Distribution Automation: RFN-1200



RFN Electric Nodes

- Up to 1 Watt power
- Multiple data rates (9.6, 19.2, 38.4, 76.8, and 153.6 kbps)
- Secure communications
- Protocols (C12.18, C12.19, Itron blurt, DR and DA protocols)
- Support two-way unicast and broadcast messaging
- Advanced Metrology Support
- Event and alarms
- Voltage profiling
- OV/UV alarms
- Blink Count, Outage
- Remote Disconnect
- Secure RSA signed Over The Air (OTA) firmware upgrades

RFN Battery Nodes

- Power 100mW to ¼ Watt
- Support multiple water registers (Badger, Elster, Itron, Neptune, Master, Mueller, Sensus, Zenner, Metron Farnier)
- Support for multiple gas registers (Honeywell, Sensus, etc)
- Connect to the network through nearby Electric or Relay node
- OTA firmware upgrade



RFN Relays

- Used to build out infrastructure to form robust mesh
- Extend RF communications into rural areas
- Build out communications network for DR, C&I or water metering before residential AMI meters are installed
- Large ultra-capacitor for outage support
- Currently 4 versions
 - RLY-806: 120-480VAC, attached external antenna or remote external antenna
 - RLY-851: 120-277VAC, internal antenna for quick deployment
 - RLY-853: 12VDC, solar energy harvesting relay
 - RLY-856: 120-277VAC, attached external antenna or remote external antenna

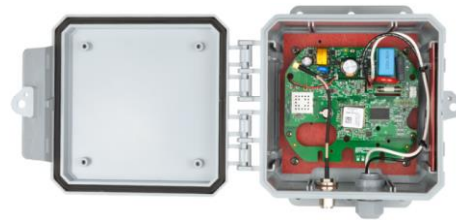

RLY-806

RFN Relays

- Various mounting options

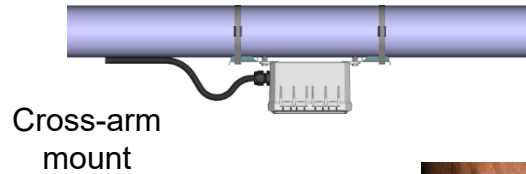

Pole
vertical
mount

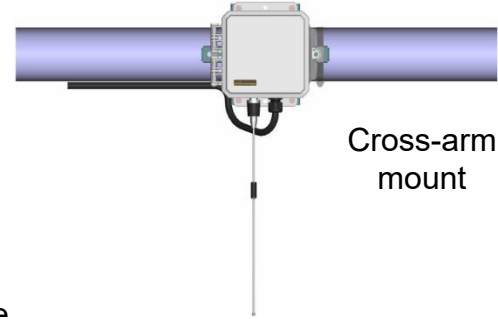

RFN WiFi Node

- Connects over IP to a service on the backend along with Yukon and Network Manager
- Behaves in the RFN as a 1-hop node to the gateway
- Supports the C2SX meter

RFN WiFi Node

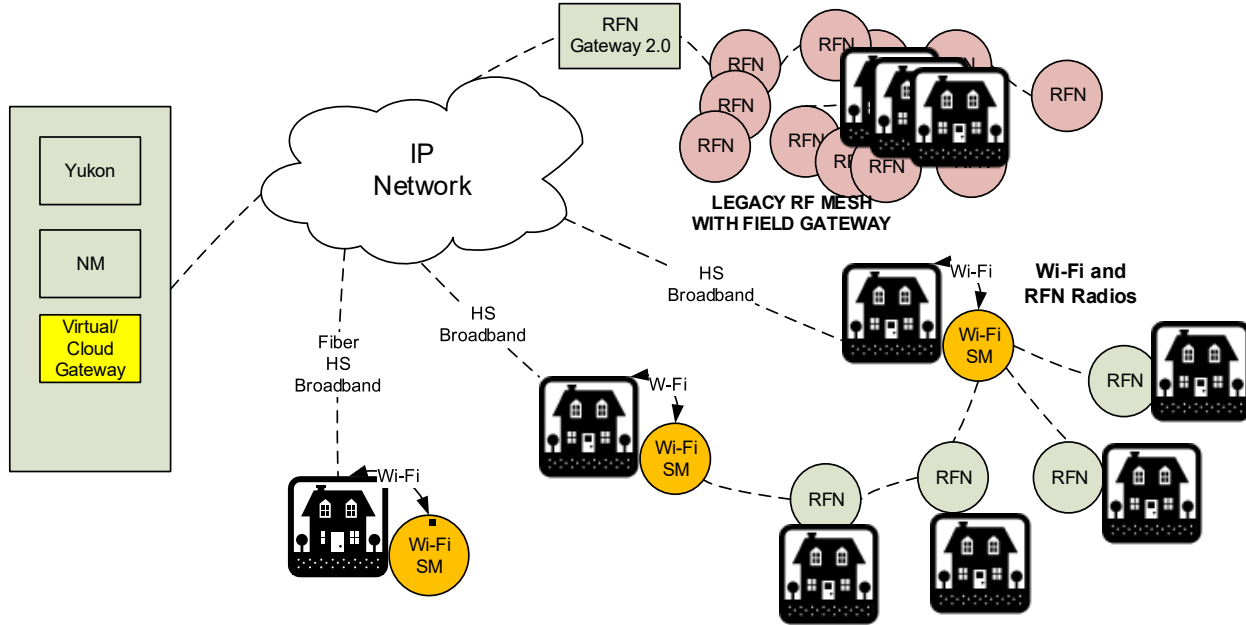

RFN Meters may have Wi-Fi capability but only RFN interface is used (i.e. Customer doesn't have Wi-Fi subscription or it is turned off, out of range etc.)



Wi-Fi SM RFN Nodes with Wi-Fi access and using Wi-Fi interface (RFN interface is also available)



RFN RFN meter with No Wi-Fi capability And working only in the legacy RFN mesh network.

RFN Network Runner



- Provides configurations and diagnostics field support
- RF Radio up to 1Watt with multiple data rates (9.6, 19.2, 38.4, 76.8, 153.6 kbps)
- Functions
 - Gateway Configuration
 - GPS provisioning for RF nodes
 - Meter management
 - LCR management
 - Water Commissioning
 - Node Firmware Upgrade
 - Network Diagnostics

Metrology and Configuration

- Residential Meters with Advanced Metrology
 - Itron C1SX, C2SX & L&G Focus
 - Advanced Metrology provides additional features to inexpensive residential meters
 - Demand calculation based on consumption
 - TOU recording with configurable schedules
 - Capability to configure TOU schedules and demand interval from Yukon
- C&I ANSI meters
 - Elster A3, Itron Sentinel & L&G S4X (future)
 - RFN Node reads configuration from meter

Meter Configuration

- Factory Configurable Items
 - Time Zone & DST
 - Recording and Reporting Intervals
 - Outage Reporting Parameters
 - C1SX & C2SX Display configuration
 - Metrics, # of digits, display cycle & disconnect state
 - Focus AL Display configuration
 - Metrics, # of digits, display cycle
 - TOU Schedules (Advanced Metrology only)
 - Demand Calculation Interval (Advanced Metrology only)

Yukon Meter Configuration

- Device Configurations are used to assign sets of configurable items to groups of meters
- Be careful when changing or assigning device configurations to large groups of meters
- Yukon Configuration Items
 - C1SX and C2SX Display configuration
 - Select metrics to display
 - # of display digits
 - Display cycle time
 - Disconnect status (C2SX only)
 - Focus AL display configuration

Yukon Meter Configuration

- Set demand interval (C1SX, C2SX, Focus)
- Set TOU schedules (C1SX, C2SX, Focus)
- Set remote disconnect configuration (C2SX & Focus AX)
- Set demand freeze date
- Metric Channel Configuration
 - Select metrics for interval recording
 - Select metrics for daily recording
 - Select interval recording and reporting time
- Set temperature alarm configuration
- Set OV/UV configuration
- Set voltage profile configuration

Remote Disconnects

- Disconnect Modes
 - On-Demand Disconnect
 - Disconnect, Arm and Reconnect
 - Load Limiting Disconnect
 - Delayed Reconnect and Immediate Reconnect
 - Cycling Disconnect
 - Off Cycle Time Can Be Different Than On Cycle Time

Frequency Hopping

- Frequency hopping enables the co-existence of multiple networks
- Hopping reduces interference due to reflection, noise and other environmental factors
- Hopping is an FCC requirement for operation on unlicensed band at 1 watt.
- The method transmits radio signal across multiple channels in a pseudo-random sequence known by the sender and receiver

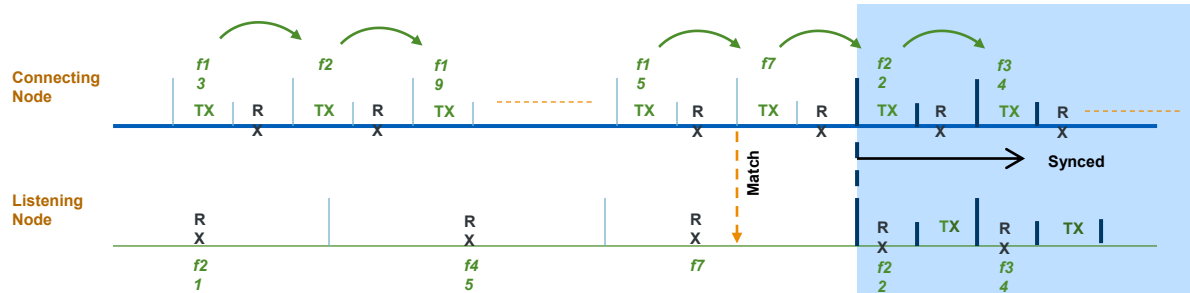

Frequency Hopping (cont'd)

- Suitable to cover larger areas where numerous co-located systems are needed
- Eaton's RF mesh nodes use 50 hopping channels per second. Uses algorithm for generating pseudo-random channels
- Eaton's RF mesh radios improves connection time using Knuth shuffle algorithm and other patented techniques such as predictive synchronization

Communications Range: Link Budget

- Combining all of the above factors -> Link Budget
 - Way of quantifying the link performance or effective range
 - TX power - (- RX Sensitivity) – Path losses = Link budget
 - Traditionally, a link budget has some amount of margin (extra capacity)

Multirate and Cost Normalization

- The link cost between node and its peer is normalized based on rate
- Supported rates = $1/8X, 1/4X, 1/2X, 1X, 2X$
 $[9.6, 19.2, 38.4, 76.8, 153.6 \text{ kbps}]$
- Lower rate = Lower Throughput = Higher Cost
- Normalization factor = rate throughput ratio

Example: In a system where 2X rate is available, the link cost at 1X rate is multiplied by 2 for normalization.

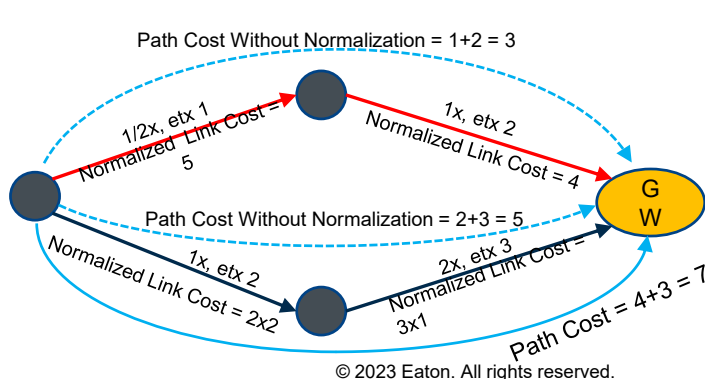

Throughput Ratio

2x:1x	2.0
1x:1/2x	2.5
2x:1/2x	5.0

Power Adaptation

- Typically support 4 power level for electric meters and relays
 - 21dBm, 24dBm, 27dBm, 30dBm
- Depends on network/device configuration
- Samples candidate power on each neighbor to evaluate the link independently
- Uses the highest power level only at the minimum rate in a high density environment
- Adjusts density based on number of surrounding devices it can receive broadcasts from

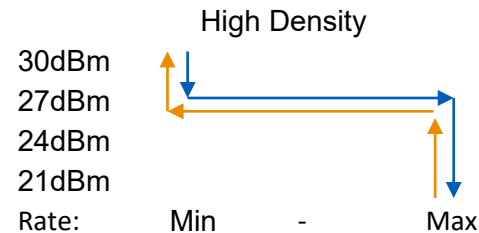
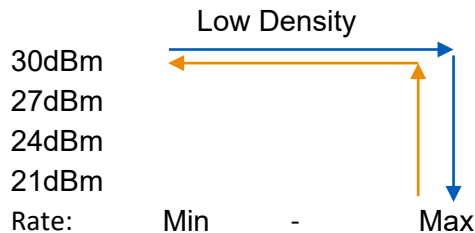

Network Simulation

- Allows the network interaction across a large population of devices to be simulated
 - Up to ~40,000, shortly simulating over ~100,000
- Varies topology to produce different loading
- Memory monitoring and address sanitization
- Future efforts include link simulation and importing network topology for simulation

EATON

Powering Business Worldwide

EATON

Powering Business Worldwide

© 2023 Eaton. All rights reserved.